

## PRODUCT INTRODUCTION

This product is a wireless photoelectronic smoke detector, hereinafter called detector. With a unique structure design and an intelligent MCU to process photoelectronic signals, it is provided with dust-proof, mothproof and anti-light interference etc. functions, ensuring the detector stability from design basis. Meanwhile, the detector could be programmed to an alarm system via wireless networking, suitable for all kinds of installation environments and enhancing users' perception of alarm signal. It reacts very quick to visible smoke released by smoldering fire and flaming fire, and suitable for fire alarm in houses, factories, shopping malls, hotels, restaurants, office buildings, teaching buildings, banks, libraries, warehouses, etc..

## PRODUCT PROFILE

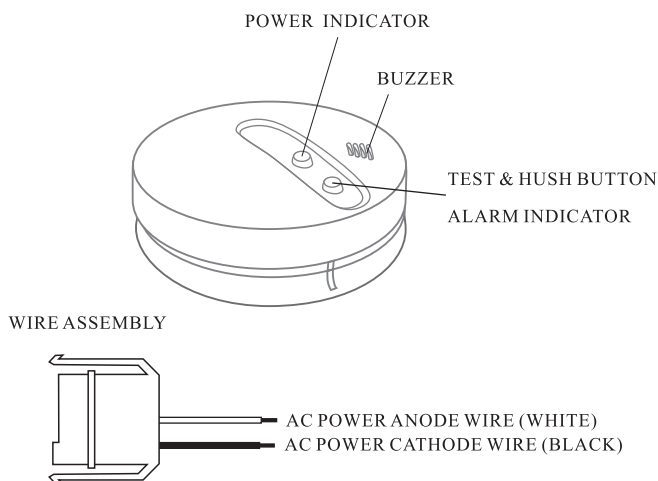

Note: If not equipped with the wire assembly, the detector is a DC TYPE.

## OPERATING PRINCIPLE

This detector adopts the principle of smoke particles reflecting infrared lights. The main circuit includes a MCU processing part, an infrared emission part and an infrared reception part. The emission and reception diodes are placed in the optical maze chamber which can shield the interference of outside stray lights, but will not influence smoke entering into the detector. On smokeless conditions, the received infrared lights are very weak. When smoke entering, due to scattering effects, the received light signals increase. When smoke density accumulates up and reach the alarm threshold of the MCU, the detector will blink its alarm indicator, give out strident alarm

sound and send out alarm signal to the networking alarm system.

## FEATURES

- Adopts MCU Auto-Processing Technology
- Wireless Networking to Alarm System
- Hush Button
- Malfunction Auto-Check
- Auto-Reset After Trigger
- Infrared Photoelectronic Sensor
- Sound & Flash Alarm / LED Indicating Alarm
- SMT Manufacture Technology, Reliable Stability
- Dust-proof, Moth-proof, Anti White Light Interference
- Anti-RF Interference (20V/m-1GHz)

## TECHNICAL PARAMETERS

Operating voltage:

- ① 9V battery (6F22 carbon battery, DC TYPE)
- ② AC220V/110V with 9V backup battery (AC TYPE)

Static current:  $\leq 20\mu\text{A}$

Alarm current:  $\leq 40\text{mA}$

Battery life: carbon battery for about 1year

Alarm indication: LED flashes in Red

Alarm sound:  $\geq 85\text{dB}/3\text{m}$

Radio frequency: 315MHz/433MHz

Code form : 2262 code

Radio transmitting distance:200m (open area)

Operating temperature:  $-10\text{ }^\circ\text{C} \sim +50\text{ }^\circ\text{C}$

Humidity:  $\leq 95\% \text{ RH}$

Dimension:  $\Phi 128*38\text{mm}$

Execution standard: GB4715-2005, EN14604, UL217

Detecting area:  $80\text{ m}^2$  at 6-12m installation height;  
 $60\text{ m}^2$  at installation height  $<6\text{m}$ .

## INSTALLATION

1. Avoid installations in places with stagnating smoke, heavy dust, heavy water mist, heavy oil mist, great humidity ( $>95\%$ ) and high wind speed ( $>5\text{m/s}$ ).
2. Insert the ready battery into the battery cabinet. Choose a proper position. Normally, the center of the detection area ceiling is recommended. Fix the detector base into the chosen position and connect the wires if the detector is a AC TYPE.

Then put the detector into the base and twist to fasten it. Be sure it is fastened tightly.

## OPERATING INSTRUCTION

### 1. Function Setup

**Jumper Setting:** use jumpers to set address code and defense zone code between the detector and the networking alarm system. A0~A7 are address code which should be the same with that of the networking alarm system. D0~D3 are data code, used to set defense zones.

### 2. Usage

- 1) Inserting the ready battery into the battery cabinet and keeping the battery power supply,
- 2) Connecting the AC power wires (for AC TYPE), the detector will enter into normal working status. The indicator flashes once per 45 seconds.

### 3. Sensitivity Test

The detector should be tested periodically to assure normal operation. Once per month is recommended. Press and hold the TEST & HUSH BUTTON for more than 1s to make the detector enter into testing status. If the alarm indicator flashes rapidly and the buzzer gives out alarm sound, then the detector works properly.

### 4. Alarm & Hush Function

When smoke density in surroundings reaches the alarm threshold of the detector, the buzzer gives out alarm sound and the alarm indicator flashes rapidly. At this time, pressing the TEST & HUSH BUTTON will make the detector enter into mute status that lasts for 10 minutes. During this period, the indicator flashes once per 10s and if the density is still higher than the threshold, the TEST & HUSH BUTTON is nonfunctional. When the smoke density goes below the threshold, pressing the TEST & HUSH BUTTON will activate the detector to perform testing operation. After the 10 minutes, the detector recovers automatically to normal working status.

### 5. Networking to Alarm System

Press the TEST & HUSH BUTTON and the detector will send out alarm signal. If use learning code alarm systems, under learning mode, users can program the detector into the alarm system by pressing the TEST & HUSH BUTTON. When an alarm occurs, users can see the alarm information from the

system and take corresponding countermeasures to reduce losses.

### 6. Malfunction Check

When the detector buzzer gives out a Di sound every 40 seconds along with the alarm indicator flashing once, the battery voltage should become lower than the detector's normal operating voltage. At this time, replace the battery with a new one. Otherwise, it will influence the detector's normal operation.

If the buzzer gives out 2 Di sounds every 40 seconds along with the alarm indicator flashing twice, the infrared photoelectronic sensor should have a malfunction. Pls contact with the dealer in time. Do not attempt to remove and repair the detector personally to prevent incidents.

## JUMPER SETTING SKETCH

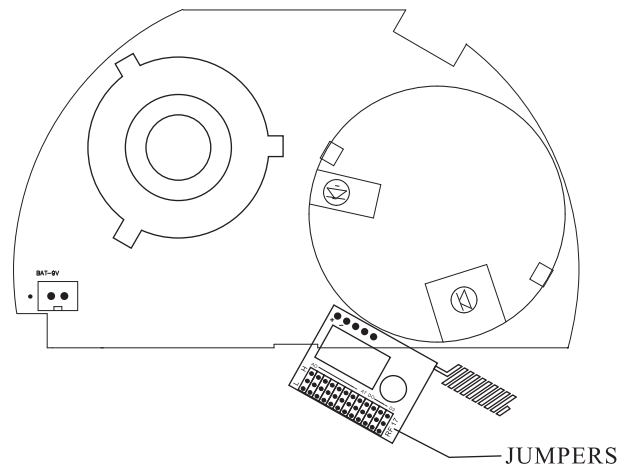

## NOTE

1. Perform the SENSITIVITY TEST as requested.
2. Clean the detector surface with soft bristled brush every 6 months to assure the detecting sensitivity. Remember to cut off the power source before cleaning.
3. If the detector is not used for a long time, remove the detector, take out the battery from the cabinet and store it in a cool and dry place.
4. The detector can reduce the happening rate of disasters. But it can not guarantee a hundred percent safe. For safety consideration, pls use the detector properly and heighten vigilance and safety consciousness to take preventive measures.