

Controlador de ascensor principal

Guia Rapida

UD03825B-C

1 Apariencia

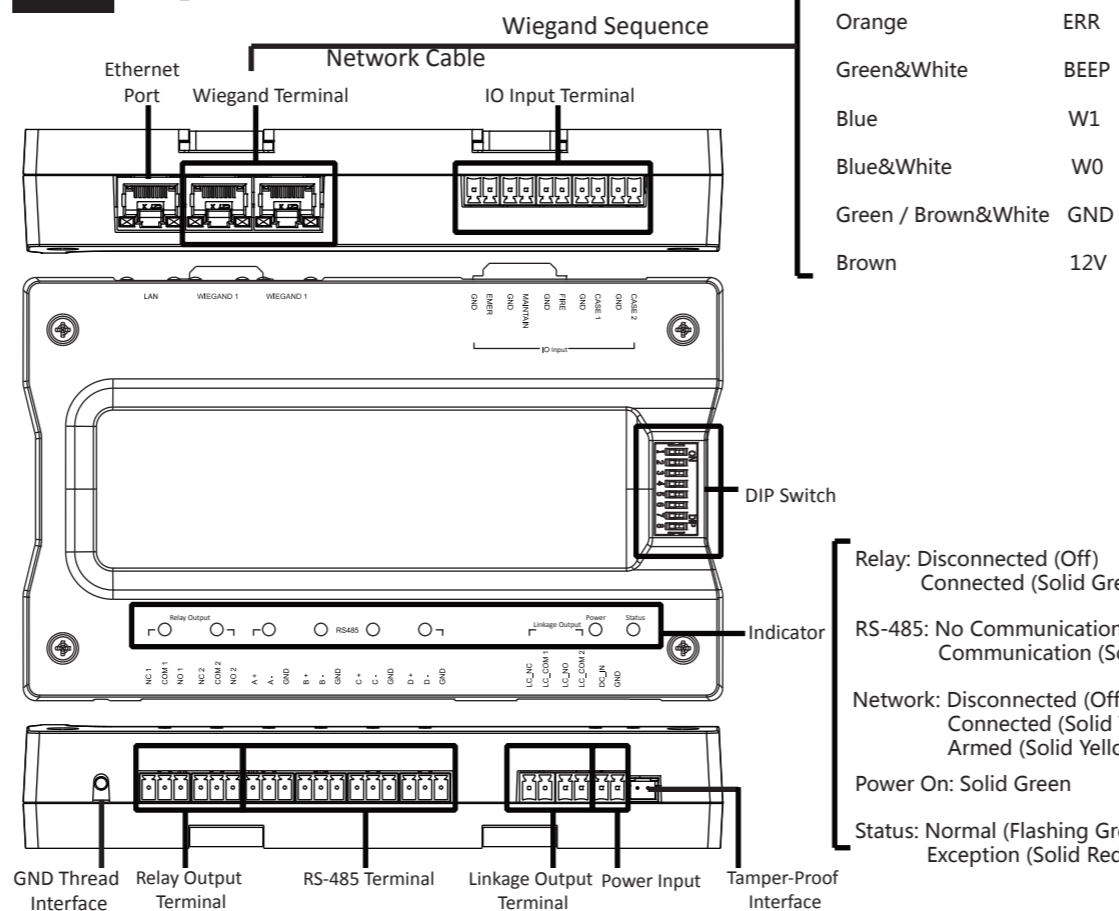

Dimensiones (mm)

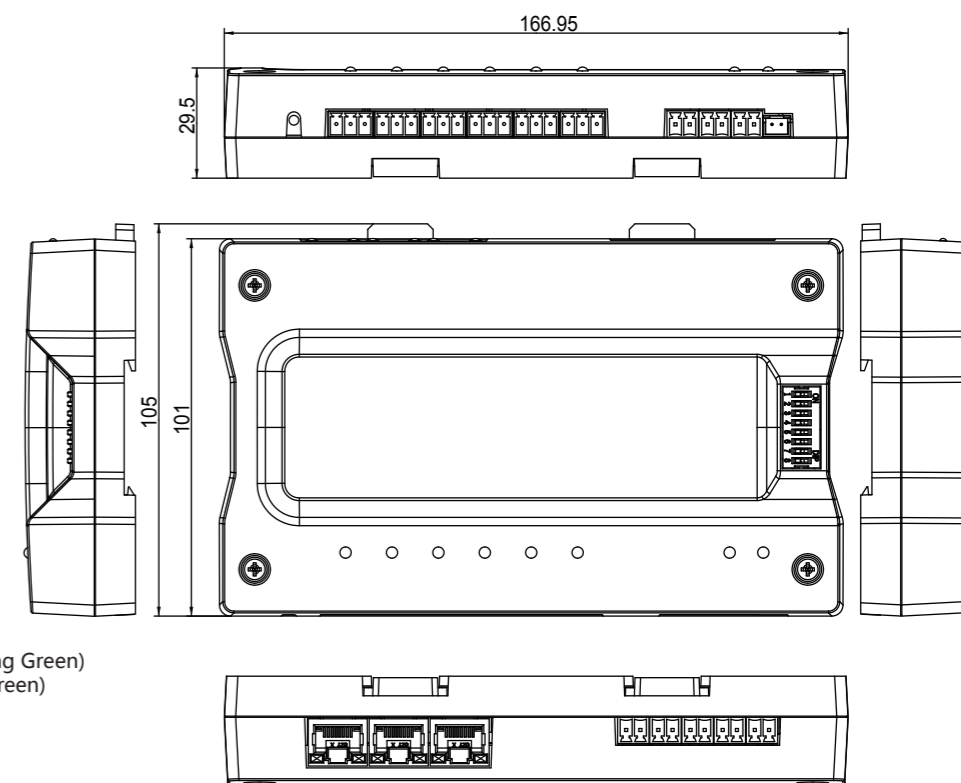

©2020 Hangzhou Hikvision Digital Technology Co., Ltd. All rights reserved. It includes instructions on how to use the Product. The software embodied in the Product is governed by the user license agreement covering that Product.

About this Manual
 The Manual includes instructions for using and managing the Product. Pictures, charts, images and all other information hereinafter are for description and explanation only. The information contained in the Manual is subject to change, without notice, due to firmware updates or other reasons. Please find the latest version of this Manual at the Hikvision website (<https://www.hikvision.com/>).

Please use this Manual with the guidance and assistance of professionals trained in supporting the Product.

Trademarks
 HIKVISION and other Hikvision's trademarks and logos are the properties of Hikvision in various jurisdictions. Other trademarks and logos mentioned are the properties of their respective owners.

Disclaimer
 TO THE MAXIMUM EXTENT PERMITTED BY APPLICABLE LAW, THIS MANUAL AND THE PRODUCT DESCRIBED, WITH ITS HARDWARE, SOFTWARE AND FIRMWARE, ARE PROVIDED "AS IS" AND "WITH ALL FAULTS AND ERRORS." HIKVISION MAKES NO WARRANTIES, EXPRESS OR IMPLIED, INCLUDING WITHOUT LIMITATION, MERCHANTABILITY, SATISFACTORY QUALITY, OR FITNESS FOR A PARTICULAR PURPOSE. THE USE OF THE PRODUCT BY YOU IS AT YOUR OWN RISK. IN NO EVENT WILL HIKVISION BE LIABLE TO YOU FOR ANY SPECIAL, CONSEQUENTIAL, INCIDENTAL, OR INDIRECT DAMAGES, INCLUDING, AMONG OTHERS, DAMAGES FOR LOSS OF BUSINESS PROFITS, BUSINESS INTERRUPTION, OR LOSS OF DATA, CORRUPTION OF SYSTEMS, OR LOSS OF DOCUMENTATION, WHETHER BASED ON BREACH OF CONTRACT, TORT (INCLUDING NEGLIGENCE), PRODUCT LIABILITY, OR OTHERWISE, IN CONNECTION WITH THE USE OF THE PRODUCT, EVEN IF HIKVISION HAS BEEN ADVISED OF THE POSSIBILITY OF SUCH DAMAGES OR LOSS.

YOU ACKNOWLEDGE THAT THE NATURE OF THE INTERNET PROVIDES FOR INHERENT SECURITY RISKS, AND HIKVISION SHALL NOT TAKE ANY RESPONSIBILITIES FOR ABNORMAL OPERATION, PRIVACY LEAKAGE OR OTHER DAMAGES RESULTING FROM CYBER-ATTACK, HACKER ATTACK, VIRUS INFECTION, OR OTHER INTERNET SECURITY RISKS; HOWEVER, HIKVISION WILL PROVIDE TIMELY TECHNICAL SUPPORT IF REQUIRED.

YOU AGREE TO USE THIS PRODUCT IN COMPLIANCE WITH ALL APPLICABLE LAWS, AND YOU ARE SOLELY RESPONSIBLE FOR ENSURING THAT YOUR USE CONFORMS TO THE APPLICABLE LAW. ESPECIALLY YOU ARE RESPONSIBLE FOR USING THIS PRODUCT IN A MANNER THAT DOES NOT INFRINGE ON THE RIGHTS OF THIRD PARTIES, INCLUDING WITHOUT LIMITATION, RIGHTS OF PUBLICITY, INTELLECTUAL PROPERTY RIGHTS, OR DATA PROTECTION AND OTHER PRIVACY RIGHTS. YOU SHALL NOT USE THIS PRODUCT FOR ANY PROHIBITED END-USES, INCLUDING THE DEVELOPMENT OR PRODUCTION OF WEAPONS OF MASS DESTRUCTION, THE DEVELOPMENT OR PRODUCTION OF CHEMICAL OR BIOLOGICAL WEAPONS, ANY ACTIVITIES IN THE CONTEXT RELATED TO ANY NUCLEAR EXPLOSIVE OR UNSAFE NUCLEAR FUEL-CYCLE, OR IN SUPPORT OF HUMAN RIGHTS ABUSES.

IN THE EVENT OF ANY CONFLICTS BETWEEN THIS MANUAL AND THE APPLICABLE LAW, THE LATER PREVAILS.

Data Protection
 During the use of device, personal data will be collected, stored and processed. To protect data, the development of Hikvision devices incorporates privacy by design principles. For example, for device with facial recognition features, biometrics data is stored in your device with encryption method; for fingerprint device, only fingerprint template will be saved, which is impossible to reconstruct a fingerprint image.

As data controller, you are advised to collect, store, process and transfer data in accordance with the applicable data protection laws and regulations, including without limitation, conducting security controls to safeguard personal data, such as, implementing reasonable administrative and physical security controls, conduct periodic reviews and assessments of the effectiveness of your security controls.

Scan the QR code to get the user manual for detailed information.
 Note that mobile data charges may apply if Wi-Fi is unavailable.

2 Instalacion

Antes de empezar

- El peso mínimo de carga de la pared u otros lugares debe ser tres veces mayor que el peso del dispositivo.
- Marque antes de instalar.

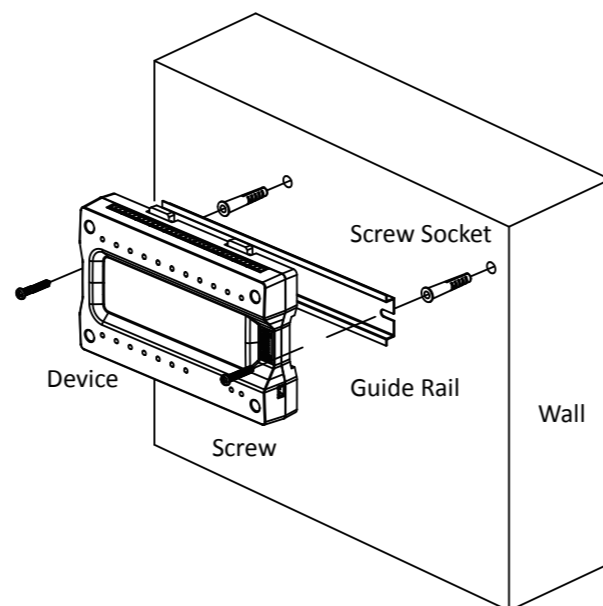

Pasos:

1. Taladre orificios en la pared u otros lugares de acuerdo con los orificios del riel guía.
2. Inserte los casquillos de los tornillos de fijación (suministrados) en los orificios perforados
3. Asegure el riel guía en la pared o en otros lugares con los tornillos (suministrados).
4. Empuje el dispositivo hacia el rail guía y fíjelo.



3 Cableado del dispositivo

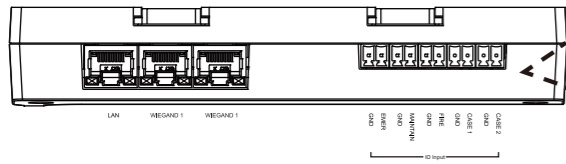

When the panic button is triggered, all relays keep connected. It is valid for all floors.
 When the fire alarm button is triggered, all relays keep disconnected. It is invalid for all floors.
 When the maintenance button is triggered, all relays keep disconnected. It is invalid for all floors.

When the panic button, the maintenance button, fire alarm button, and the event alarm are triggered, the main elevator controller will control the distributed controller via the linkage output to perform the linked actions.

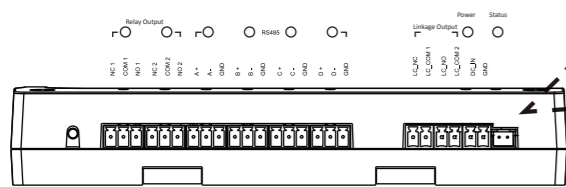

Each main elevator controller supports up to 24 distributed elevator controllers, including 8 call elevator distributed controllers, 8 auto button distributed controllers, and 8 button distributed controllers.

- The maximum power supply for the relay is DC 30 V, 2 A or AC 125 V, 0.5A.
- Confirm with elevator manufacturers on wiring methods to avoid faults caused by wrong wiring.

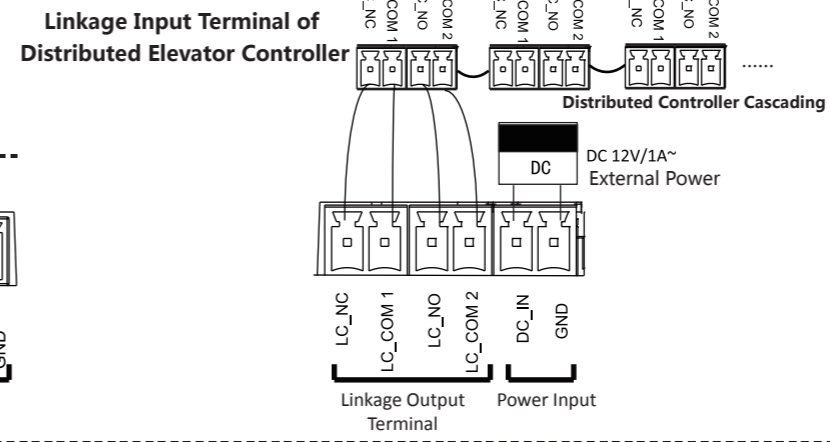
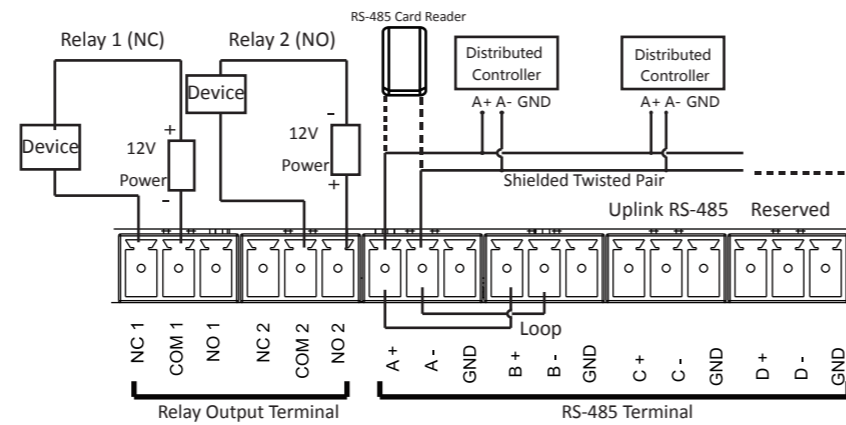
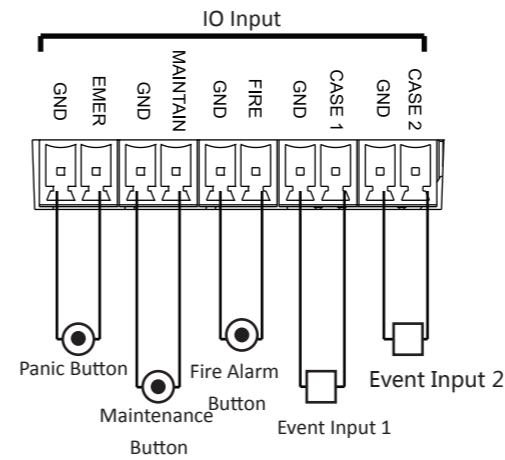
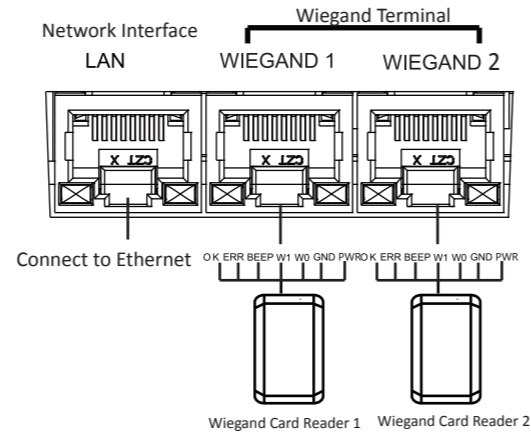

4 Activacion

Se admite la activación a través del cliente web, la herramienta SADP y el software del cliente.

● Activación del dispositivo a través del cliente web

1. Ingrese la dirección IP del dispositivo en la barra de direcciones. Para el primer inicio de sesión, el cliente web ingresará a la interfaz de activación. La dirección IP predeterminada del dispositivo: 192.0.0.64
2. Introduzca el nombre de usuario y la contraseña de acuerdo con las sugerencias de la interfaz.
3. Confirme la contraseña.

● Activating Device via SADP Tool

1. Descargue el software SADP: Obtenga el software SADP del disco suministrado o del sitio web oficial. Instale y ejecute el software
2. Activar dispositivo: Compruebe el dispositivo inactivo de la lista de dispositivos. Cree una contraseña en el lado derecho de la interfaz y confírmela.
3. Edite la dirección IP del dispositivo: Verifique el dispositivo y edite manualmente la dirección IP del dispositivo, el número de puerto, la máscara de subred, la puerta de enlace, etc.

● Activación del dispositivo a través del software del cliente

1. Haga clic en el icono de Administración de dispositivos para ingresar a la interfaz de Administración de dispositivos.
2. Seleccione un dispositivo inactivo de la lista de dispositivos. Haga clic en Actvate para abrir la interfaz de Actvaton.
3. Cree una contraseña y confirme la nueva contraseña. Haga clic en Aceptar para iniciar la activación. 4. Haga clic en "Editar red" para configurar la dirección IP del dispositivo, la dirección de la máscara, la dirección de la puerta de enlace, el número de puerto.

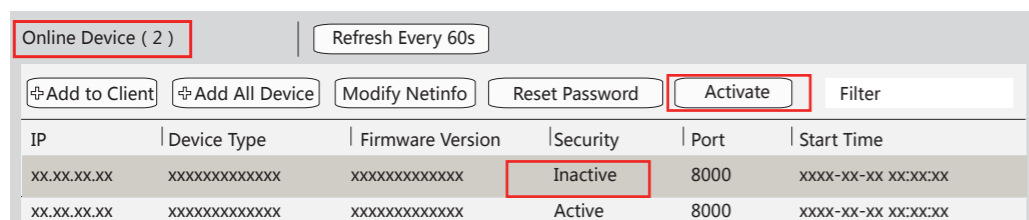
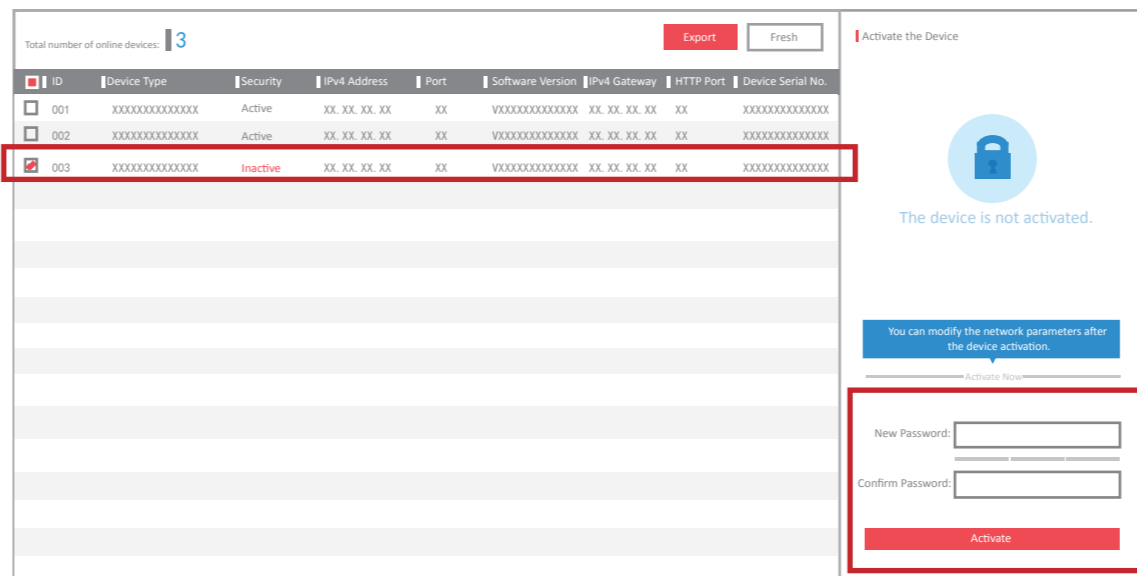

Regulatory Information

FCC Information

Please take attention that changes or modification not expressly approved by the party responsible for compliance could void the user's authority to operate the equipment.

FCC compliance: This equipment has been tested and found to comply with the limits for a Class B digital device, pursuant to part 15 of the FCC Rules. These limits are designed to provide reasonable protection against harmful interference in a residential installation. This equipment generates, uses and can radiate radio frequency energy and, if not installed and used in accordance with the instructions, may cause harmful interference to radio communications. However, there is no guarantee that interference will not occur in a particular installation. If this equipment does cause harmful interference to radio or television reception, which can be determined by turning the equipment off and on, the user is encouraged to try to correct the interference by one or more of the following measures:

- Reorient or relocate the receiving antenna.
- Increase the separation between the equipment and receiver.
- Connect the equipment into an outlet on a circuit different from that to which the receiver is connected.
- Consult the dealer or an experienced radio/TV technician for help.

This equipment should be installed and operated with a minimum distance 20cm between the radiator and your body.

FCC Conditions

This device complies with part 15 of the FCC Rules. Operation is subject to the following two conditions:

1. This device may not cause harmful interference.
2. This device must accept any interference received, including interference that may cause undesired operation.

EU Conformity Statement



This product and - if applicable - the supplied accessories too are marked with "CE" and comply therefore with the applicable harmonized European standards listed under the RE Directive 2014/53/EU, the EMC Directive 2014/30/EU, the RoHS Directive 2011/65/EU.



2012/19/EU (WEEE directive): Products marked with this symbol cannot be disposed of as unsorted municipal waste in the European Union. For proper recycling, return this product to your local supplier upon the purchase of equivalent new equipment, or dispose of it at designated collection points. For more information see: www.recycle-this.info



2006/66/EC (battery directive): This product contains a battery that cannot be disposed of as unsorted municipal waste in the European Union. See the product documentation for specific battery information. The battery is marked with this symbol, which may include lettering to indicate cadmium (Cd), lead (Pb), or mercury (Hg). For proper recycling, return the battery to your supplier or to a designated collection point. For more information see: www.recyclethis.info

Use only power supplies listed in the user instructions:

Model	Manufacturer	Standard
C2000IC12.0-24P-DE	MOSO Power Supply Technology Co., Ltd.	CEE
C2000IC12.0-24P-GB	MOSO Power Supply Technology Co., Ltd.	BS